

# SIMULIA

## COMMUNITY NEWS

---

#08 October 2014

### THE POWER OF THE PORTFOLIO

**COVER STORY**  
SIMULATION  
HELPS UPGRADE  
LONDON TUNNELS

 **DASSAULT  
SYSTEMES** | The **3DEXPERIENCE**® Company



10 | DR. SAUER

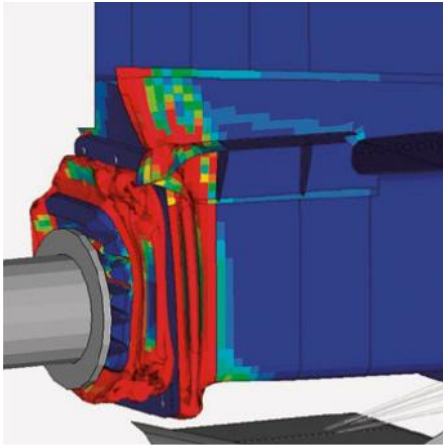

14 | STADLER



18 | WÖLFEL

# in this Issue

October 2014

## 3 Welcome Letter

Scott Berkey, Chief Executive Officer, SIMULIA

## 4 Portfolio Update

Latest SIMULIA Portfolio Releases Deliver Powerful, Advanced Simulation Functionality to Users

## 8 Strategy Overview

How to Stay at the Top of Your Game in the Fast-Evolving World of Simulation

## 10 Cover Story

Dr. Sauer and Partners Helps Upgrade London Underground Station

## 13 News

SIMPACK Joins the Dassault Systèmes Family

## 14 Case Study

Stadler Rail Simulates Train Safety with FEA

## 17 Alliances

Topology and Shape Optimization Using the Tosca-Ansa Environment

## 18 Case Study

Fine-tuning the Anatomy of Car-Seat Comfort

## 20 Academic Update

Oil & Gas Subsurface Innovation with Multiphysics Simulations

## 22 Tips & Tricks

Optimization Module Within Abaqus/CAE

**Contributors:** Dr. Alois Starlinger (Stadler Rail), Dr. Alexander Siefert (Wölfel Group), Jeremy Brown and Randi Jean Walters (Stanford University), Parker Group

**On the Cover:** Ali Nasekhian, Dr. techn., M.Sc. Senior Tunnel Engineer, Dr. Sauer and Partners  
Cover photo by Roger Brown Photography

*SIMULIA Community News* is published by Dassault Systèmes Simulia Corp., Rising Sun Mills, 166 Valley Street, Providence, RI 02909-2499, Tel. +1 401 276 4400, Fax. +1 401 276 4408, [simulia.info@3ds.com](mailto:simulia.info@3ds.com), [www.3ds.com/simulia](http://www.3ds.com/simulia)  
**Editor:** Tad Clarke **Associate Editor:** Kristina Hines **Graphic Designer:** Todd Sabelli

©2014 Dassault Systèmes. All rights reserved. **3DEXPERIENCE**, the Compass icon and the 3DS logo, CATIA, SOLIDWORKS, ENOVIA, DELMIA, SIMULIA, GEOVIA, EXALEAD, 3D VIA, BIOVIA, NETVIBES, and 3DXCITE are commercial trademarks or registered trademarks of Dassault Systèmes or its subsidiaries in the U.S. and/or other countries. All other trademarks are owned by their respective owners. Use of any Dassault Systèmes or its subsidiaries trademarks is subject to their express written approval.

 **SIMULIA**



## **SIMULIA'S GROWING COMMUNITY— AND CAPABILITIES**

**E**arlier this year, I had the chance to meet with many of you at the SIMULIA Community Conference in Providence, RI. At each SCC, I am always humbled by the excellent presentations by our valued user community. With more than 70 user papers and keynote addresses from adidas, Pratt & Whitney, DuPont/Bodie Technology and a special guest affiliated with both Harvard University and MIT, it is clear that technology plays a critical role in research and development advances that improve our lives and help to create a sustainable future. You can access the 2014 SCC Proceedings online in the SIMULIA Learning Community.

It's because of your engineering requirements and proactive feedback that we continue to expand our technology portfolio. By working closely with you, we are making investments in technology that we hope will provide additional value as you strive to meet your business objectives.

As evidence of Dassault Systèmes' ongoing commitment to provide enhanced and broader simulation capabilities to our community, SIMULIA recently launched, simultaneously – for the first time – the new releases of Abaqus, fe-safe, Isight and Tosca. You can learn more about these new features online and at our fall Regional User Meetings. We have also made all of these products accessible through Extended Packaging, which allows you to leverage the technology you need – when you need it, rather than going through additional purchasing processes.

We also recently expanded our portfolio to include multibody simulation with the acquisition of SIMPACK. Many world-leading manufacturers in the automotive, railway, engine, wind turbine, power transmission and aerospace industries use SIMPACK to handle complex models, nonlinear effects such as friction and flexible structures, efficient numerical algorithms and real-time capabilities. In the near future, this technology, combined with our current portfolio and the integration with Dymola system simulation technology from Dassault Systèmes, will enable you to simulate and optimize not only components, but complete mechanical systems.

This magazine, along with the abundance of papers presented at the SCC clearly demonstrate how our community is adding value to their industries and creating a wealth of benefits for our society! Thanks to all of you for participating and for sharing your stories.

Please keep the dialogue going at a more local level by attending a Regional User Meeting near you (see the RUM schedule on the inside back cover for more details). I look forward to meeting with you and learning more about your technology and business requirements.

**SCOTT BERKEY**  
*Chief Executive Officer, SIMULIA*



# Portfolio Update

## LATEST SIMULIA PORTFOLIO RELEASES DELIVER POWERFUL, ADVANCED SIMULATION FUNCTIONALITY TO USERS

Expanded capabilities in Abaqus, Tosca, fe-safe and Isight produce optimal, durable designs

The power of the SIMULIA Portfolio has come into full force with this summer's release of the latest versions of Abaqus, Tosca, fe-safe and Isight. Not only do these products deliver industry-leading capabilities, but they are now integrated with each other to an extent never before possible. Together they provide SIMULIA users with expanded capabilities to simulate product performance as well as to improve and to virtually validate product designs so they are optimal and durable.

The SIMULIA Portfolio offers technology in finite element analysis (Abaqus); topology and shape optimization (Tosca Structure); fluid-channel topology optimization (Tosca Fluid); durability and fatigue evaluation (fe-safe®); and Design-of-Experiments, parameter optimization and process capture enabling the entire simulation sequence to be re-used (Isight).

### What does such a powerful portfolio bring to you?

- Reductions in time-consuming, costly physical testing.
- Increased confidence that your products will pass real-world testing and more certainty that they will perform as desired.
- Deeper knowledge of your entire design space, so you know your final results are optimal and robust.
- Greater product durability and longer lifespan.
- Increased design-to-production efficiency so you'll know you have designed the best possible product from the least material at the lowest cost.

While Abaqus, Tosca, fe-safe and Isight are separate programs—and still available as such—we unified the licensing of all of them earlier this year through our extended packaging offering. Now you can have interactive access to all SIMULIA's model building, visualization, and pre- and post-solution processors through a single pool of Abaqus/CAE Extended Tokens. More importantly, this also gives you the full-solution capability

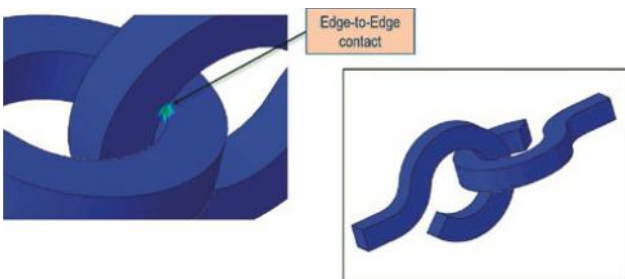

New edge-to-edge contact capability (including beam-to-perimeter-edge and beam-to-feature-edge) in Abaqus 6.14 allows expanded flexibility in complex multibody interaction, assembly and mechanism simulation, particularly for Industrial Equipment, Transportation & Mobility and Life Science industries

of all these programs (Abaqus, Tosca Structure, Tosca Fluid, Isight and fe-safe) even if only one product is purchased. The worth of your simulation investment is augmented through immediate access to the core technologies in our portfolio.

SIMULIA has now gone far beyond simple stress analysis to provide the widest, deepest, best-in-class suite of simulation technologies for the specialist user available in the market today. For complete details about the latest enhancements, go to [www.3ds.com/products-services/SIMULIA/portfolio](http://www.3ds.com/products-services/SIMULIA/portfolio). Here is an overview that shows how the Power of the Portfolio can benefit you.

### THE FOUNDATION: ABAQUS UNIFIED FEA

As an Abaqus user, you are working with the world's technology-leading suite of finite element analysis (FEA) software for modeling, visualization and best-in-class implicit and explicit dynamics. The SIMULIA suite of scalable, unified analysis products allows all our customers, regardless of their simulation expertise or domain focus, to collaborate and seamlessly share simulation data and approved methods without loss of information fidelity. By contrast, when multiple vendor, niche simulation tools are employed to simulate a variety of design attributes, inefficiencies and increased costs can result.

With the Abaqus Unified FEA suite—Abaqus/CAE, Abaqus/Standard and Abaqus/Explicit—you can access powerful and complete solutions for both routine and sophisticated engineering problems covering a vast spectrum of industrial applications. For example, in the automotive industry, engineering work groups can consider full-vehicle loads; dynamic vibration; multibody systems; impact/crash; nonlinear static loads; thermal, and acoustic-structural, coupling—all using a common model data structure and integrated solver technology.

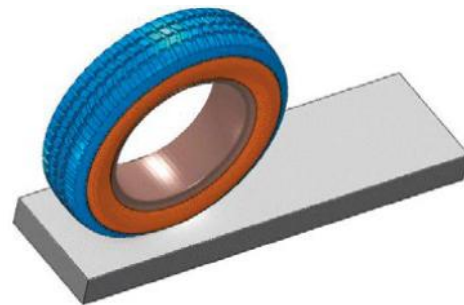

Domain parallelization for DEM technology as well as hyperelastic material and Adaptive Mesh Refinement (AMR) functionality for CEL methods provides expanded application capability in many fluid-structure interaction applications across many industries.



Leading companies around the world take advantage of Abaqus Unified FEA to consolidate their processes and tools, reduce costs and inefficiencies, and gain competitiveness. The resulting benefits include a reduction in a company's FEA toolset and training expenses, greater efficiency in model generation, improved correlation between test and analysis results, improved data transfer between simulations and a more flexible workforce that has greater bandwidth for innovation.

### What's New in Abaqus 6.14

- **Contact**—Now edge-to-edge contact is extended to include feature edges on solid and shell-like surfaces, and shell perimeter edges, for more automated and robust resolution of contact between edges. Previously only beam-to-beam contact was supported.
- **Output**—Since the **3DEXPERIENCE** platform is being integrated with the SIMULIA portfolio, you can now write results to a SIM database as well as in the traditional ODB format. This allows analyses to be visualized on the **3DEXPERIENCE** platform for wider collaboration.
- **AMS eigensolver performance improvements**—The AMS eigensolver can now use compute-capable GPGPU cards to reduce the run time for frequency extraction analyses for large-scale models.
- **Materials**—A new parallel creep model for rate-dependent behavior, such as pressure and total deformation, improves nonlinear viscoelastic analyses. Coupled Eulerian Lagrangian analysis can now be performed with anisotropic materials.
- **Crack modeling**—The XFEM method can now be extended to include pore pressure degrees of freedom. This capability is very useful to accurately assess the hydraulic fracture process in the Oil & Gas industry as well as fluid flow in the Life Sciences and Consumer Goods industries.
- **Fluid analysis**—An enhanced  $k-\epsilon$  turbulence model provides greater detail for modeling fluid-flow problems more intuitively and flexibly.
- **Optimization**—SIMULIA Isight is at the core of our parametric optimization tools; the integration of Tosca Structure within Abaqus/CAE has expanded our arsenal into the realm of non-parametric optimization (see the Tosca section later in this article). In Abaqus/CAE, in addition to topology and shape optimization, you can now create sizing optimizations of sheet structures by modifying the thickness of the shell elements.

The optimization module within Abaqus/CAE now supports the use of multiple nonlinear load scenarios to be considered within one optimization task. Improved postprocessing offers additional settings to influence the number of stored intermediate results and accelerated result combination at the end of the optimization process. A new design response called energy stiffness measure has been introduced to simplify stiffness-optimizations for combined-load scenarios. Some Abaqus/CAE geometry and modeling and visualization

features have been enhanced to improve the efficiency to create your model and visualize the simulation results.

### OPTIMIZE AND AUTOMATE WITH ISIGHT AND SEE

Isight is SIMULIA's industry-leading process automation and design optimization solution that enables users to reduce analysis time and costs while improving product performance, quality and reliability. SIMULIA Execution Engine (SEE) is based on state-of-the-art Fiper technology for distributing and parallelizing simulation process flows in a high-performance manner that takes advantage of a company's existing hardware and software investments.

When used in conjunction with SEE, Isight lets customers build a web-based framework for distributing the execution of simulation processes across the enterprise to optimize computing resources and to enable collaboration among geographically distributed users.

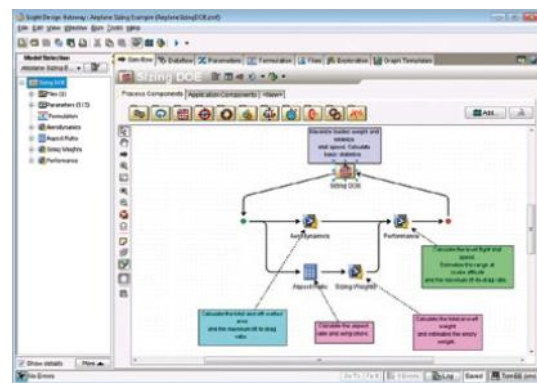

Isight Design Gateway Connected to TomEE Based SEE

### You benefit from these technologies in a number of ways:

- Easily automate simulation process flows.
- Leverage advanced techniques such as design of experiments (DOE), optimization, approximation and design for Six Sigma.
- Optimize your designs for cost, weight, materials and more.
- Engage your hardware and computing resources at optimum levels.
- Integrate seamlessly with your enterprise Web application servers and databases.

### What's New in Isight 5.9

For Isight, the new release further enhances certain components connecting to third-party tools and installation procedures. For SEE, this release enhances infrastructure to provide better control over execution of complex processes.

New functionality in Isight lets you use Excel to generate your design matrix with a dedicated plug-in for importing data. Previously the DOE component only supported ASCII text files. There are a number of component updates: 5.9 now supports CATIA V5 R21 through R24. The Mathcad component has been improved to handle variables with units. Support has been added for third-party workbenches.

# Portfolio Update

## Big News in SEE 5.9

There's big news in SEE: it now supports the open-source web-application server TomEE and the open-source database Derby. These two, free middlewares are now shipped with SEE and are easily deployed with the SEE installer. Unlike the previous Websphere or Weblogic servers, no separate prerequisite software needs to be installed.

Personal SEE is also now bundled in Isight so, for your own use, you don't need to pay an additional license fee.

## TOSCA OPTIMIZATION TECHNOLOGY: STRUCTURAL AND FLOW OPTIMIZATION SOLUTIONS

The Tosca Optimization Suite provides fast and powerful non-parametric structural and flow optimization solutions based on FEA and CFD simulations.

Tosca Structure helps you design lightweight, stiff and durable parts and assemblies with shorter development cycles so you can maximize performance, minimize material and weight, and discover new design possibilities. You can identify the design with maximum stiffness and/or minimum weight, reduce mass through optimized sheet thickness, reduce local stresses and increase durability, and increase stiffness or eigenfrequency of sheet structures.

And now, with the full integration of fe-safe within Tosca (for more details on fe-safe itself see the fe-safe section below), you can also use fe-safe fatigue results within your shape optimizations.

Tosca Fluid helps you develop topology-optimization driven design concepts for fluid-flow systems and components. Use its capabilities to create innovative design ideas automatically for a defined flow task and available design space—with optimization of channel flow to reduce pressure drop. Tosca Fluid's unique technology helps you achieve the highest flow performance, quality and eco-efficiency.

### The benefits of using Tosca Structure and/or Tosca Fluid are many:

- Accelerate conceptual design and reduce time-to-market.
- Support ready-to-manufacture product design.
- Save weight and ensure the highest result quality for reliable components.
- Avoid error-prone, time-consuming model simplification.
- Apply realistic simulation and handle nonlinearities directly within the optimization.
- Define optimization tasks interactively in intuitive graphic user interfaces.
- Create fluid-flow devices with reduced pressure drop and improved flow uniformity.

### What's New in Tosca

If you haven't yet tried Tosca Optimization and would like to explore these benefits further, remember that you can now

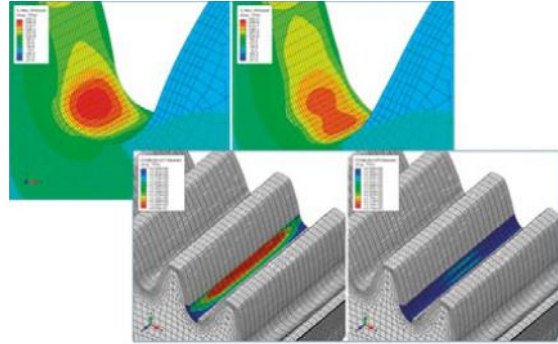

Durability Analysis within Structural Optimization

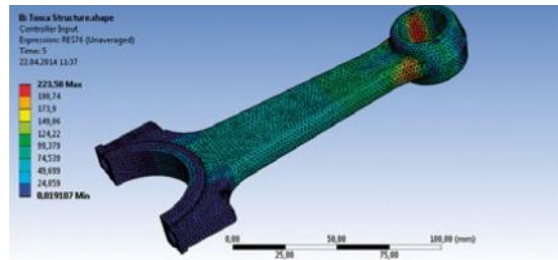

New! Shape and Topology Optimization

try out Tosca Structure and/or Tosca Fluid optimization tools at no extra cost when you're on an Extended Token license with Abaqus or Isight.

Tosca Structure 8.1 enhancements include: With the Optimization Module in Abaqus/CAE Tosca Structure topology, sizing and shape optimization tasks are now directly integrated into Abaqus/CAE. Author, run and postprocess your optimization tasks within your already known graphical user interface. Support of fe-safe analysis to use in shape optimization—including a new durability solver interface that provides a ready-to-use integration of fe-safe fatigue results into Tosca Structure. Improved internal data handling, eased stiffness optimization with added thermal loading consideration. Enhanced mesh smoothing for shape optimization using element correction. And improved soft-delete algorithms for optimizations with highly nonlinear geometrical models.

Tosca Fluid 2.4 enhancements include accessibility through SIMULIA Extended Packaging (Extended Tokens), updated CFD solver interfaces for STAR-CCM+ and ANSYS Fluent, as well as postprocessing enhancements like refinement of slices near flow boundaries and an added method for filtering slices based on particle tracks.

## SIMULIA fe-safe RELEASES WITH ABAQUS FOR THE FIRST TIME

Also available with SIMULIA Extended Tokens, fe-safe is a powerful, comprehensive, easy-to-use suite of fatigue analysis software for finite-element models. It can be used alongside Abaqus—or any commercial FEA software—to calculate where fatigue cracks will occur and when they will initiate, the factors of safety on working stresses (for rapid

optimization), the probability of survival at different service lives (the “warranty claim” curve) and whether cracks will propagate.

fe-safe is used by leading companies in automotive, heavy truck, off-highway, marine, defense, offshore, power generation, wind energy, medical engineering and many other industries. Typical applications include the analysis of machined, forged and cast components in steel, aluminum and cast iron, high-temperature components, welded fabrications and press-formed parts.

By adding fe-safe to your simulation toolkit, you will be able to increase the fatigue life of safety-critical components, optimize your designs to use less material, reduce product recalls and warranty costs, optimize and validate design and test programs, improve correlation between test and analysis within a single-user interface, reduce prototype test times, speed up analyses and reduce man-time hours, reduce reliance on physical testing and increase confidence that your product designs will past their test schedules as “right-first-time.”

#### fe-safe provides many benefits to users:

- New levels of accuracy for the analysis of structural welds, seam welds and spot welds.
- Newly added vibration fatigue features. It can export fatigue damage for each block of loading, enabling clear identification of which parts of the duty cycle are contributing the most fatigue damage, for re-design purposes.
- fe-safe also reads FEA results from forming or assembly processes to estimate residual stresses for rapid sensitivity analysis. Signal processing, load history manipulation, strain gauge fatigue, and generation of accelerated testing signals are all included as standard features.
- A mesh-insensitive structural stress method predicts failure locations and calculates fatigue life for welded joints and structures.
- The fe-safe material database provides a comprehensive library of fatigue properties for commonly used materials.

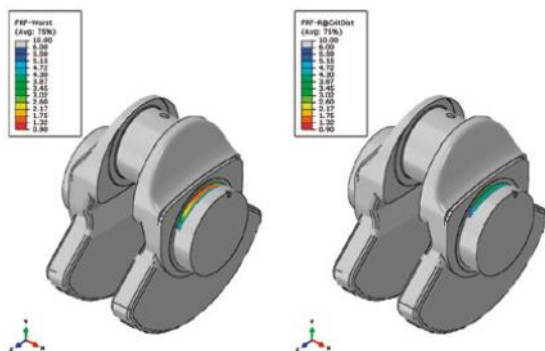

Left Image: Factor Of Strength for crack initiation FOS<1 Design fails.  
Right Image: Increased Factor Of Strength based on TCD analysis FOS>1 Design passes.

## ACADEMIC PORTFOLIO NEWS

The Power of the Portfolio is as compelling on campus as it is in industry. Top engineering programs demand cutting-edge technology and our customers want engineers with the skills and experience to make an immediate contribution. The SIMULIA Academic Portfolio has been updated with two new products to address these needs:

- **SIMULIA Academic Research Suite** – Commercial-level functionality for highly sophisticated research. Custom licensing options ensure the right license is available for a single user, an entire campus and everything in between.
- **SIMULIA Academic Teaching Suite** – Feature-rich educational licenses for classrooms and computer labs with minor limitations compared to the Research Suite. Node limits have been increased to 250K!

Both Suites feature Extended Tokens, providing access to Abaqus, Isight, Tosca, fe-safe, and the Associative Interfaces for CATIA and SolidWorks.

SIMULIA believes a strong academic program is essential to the success of our business, your business, and to the academic institutions we serve. *Please visit our Academic home page at [www.3ds.com/products-services/SIMULIA/academics/](http://www.3ds.com/products-services/SIMULIA/academics/) to learn more about our program.*

## What's New in fe-safe 6.5

As mentioned, the fe-safe fatigue solver can be licensed via Extended Tokens. This includes Distributed Memory Parallel (DMP). The new vibration fatigue capability allows fe-safe to work completely in the frequency domain with its critical-plane fatigue technology. This helps you analyze fatigue lives from FEA dynamic models of flexible structures at a very fast rate—orders of magnitude faster than working in the time domain.

fe-safe now provides support for 1st and 2nd order Hex and Tet meshes, allowing you to design based on non-propagation of cracks instead of on crack initiation. This can result in lighter components and is particularly valuable when working with cast iron. There's also improved handling of TCD ray tracing with collapsed elements, and the inclusion of temperature-dependent material properties as well as accuracy improvements in the line method. You can now model large models with long, complex fatigue loading, thanks to distributed processing available through Extended Tokens. And you can copy materials between databases in order to more easily modify parameters.

If you have further questions about any of the new SIMULIA Portfolio releases or the Extended Token offering, please see [www.3ds.com/products-services/SIMULIA/portfolio/extended-token-licensing](http://www.3ds.com/products-services/SIMULIA/portfolio/extended-token-licensing) or contact your SIMULIA vendor.

### For More Information

[www.3ds.com/SCN-September2014](http://www.3ds.com/SCN-September2014)



# Strategy

## HOW TO STAY AT THE TOP OF YOUR GAME IN THE FAST-EVOLVING WORLD OF SIMULATION

What the Power of the Portfolio really means for SIMULIA customers



By Sumanth Kumar  
Vice President Portfolio Experience

Whatever industry you work in, producing the best products means mastering a range of design engineering domains. Ultimately, your company will need to unite these disciplines toward optimizing performance attributes against cost and product lifetime to deliver the best overall user experience. Every step in the development process is targeted toward answering the questions:

- Will this product work as intended?
- How long will it last?
- What will our customers think about it?

You will typically distill that down to a series of analyses that systematically reveal the best answers to each question in your area of focus, and then merge it with those answers obtained from your colleagues to get a complete picture.

We get it. We've heard your concerns and are evolving to better meet your needs in today's world to help you deliver tomorrow's best products. At SIMULIA, we also have experts in our silos of knowledge, but we too must broaden our scope and increase our levels of integration to deliver the synergies you need to meet your goals.

We know it's no longer sufficient to simply mesh a product model, deliver stress and deformation plots and then move on to another project. You are expected to do more, to take the next step and to extrapolate what you have learned to predict

durability and lifespan or estimate the operating range for a given design or family of designs or even suggest alternate designs that will perform better or more reliably. Today, you need to provide more complete answers—and do it even sooner than ever before. And those who grow their skill sets to deliver these results will advance faster and grow the use of simulation in their organizations.

### ACCESS THE TOOLS YOU NEED

With these increasing demands, we see great opportunities for our customers. We have always been committed to providing technology to solve your toughest problems. You've noticed that we have been accumulating exceptional technology and knowledge from companies that were previously partners, but now as part of SIMULIA can help share their experience to improve your productivity. We are now busy assembling them into the most useful toolkit possible to address the "pain points" that affect performance, production and profitability.

Our software portfolio of leading products has indeed grown, now including Abaqus, Isight, Tosca, fe-safe®, Simpor Mold and SIMPACK. Over time, these will all be available in an integrated environment on the **3DEXPERIENCE** platform. But your challenges are today ... so to help you begin to realize the potential of this portfolio of products, we have introduced a flexible way to gain access to many of them with a single license, what we call "Extended Tokens." When you

choose this licensing scheme, a single-token pool gives you full access to our core simulation group of product families: Abaqus, Isight, Tosca and fe-safe.

Using Extended Tokens, you no longer need to decide up front which of these technologies you will need and for how long. (For example, if you are using Abaqus 6.14, you also have access to Isight 5.9, Tosca Structure 8.1, Tosca Fluid 2.4, and fe-safe 6.5 for as much as your token pool will allow. Please see page 4 of this issue for details about the most recent releases of all these portfolio products.) This will allow you to use products you may be unfamiliar with and determine for yourself when and where they can help you. No need to go back and request software you didn't know you needed originally. You can explore the tools that can help you work more efficiently, solve new problems while broadening your skill set and increase your value within the company.

So how does the use of the SIMULIA Portfolio help you do your job better? Here are just a few examples from life sciences, aerospace and industry.

### **MAKING A HEART STENT MORE DURABLE**

For a medical device that is being implanted into a human being, the critical question all stent manufacturers must answer is, "What is its fatigue life and how many years will it last in a living patient?" SIMULIA recently addressed this question using the combination of Abaqus, Tosca, fe-safe and Isight on a generic stent design. Abaqus identified areas of stress concentration. Tosca refined the geometry of the stent, showing where material could be removed to decrease stress in the most critical areas. fe-safe examined durability before and after the application of Tosca, revealing a significant increase in product life expectancy after the Tosca analysis. Finally, Isight carried out a design-space study that optimized stent design versus costs and helped us reach the best possible result with the bottom line in mind.

### **QUADCOPTER FLIGHT PLAN: FROM CONCEPT TO AIRBORNE**

Those of you who attended this year's SIMULIA Community Conference in Providence saw the Power of the Portfolio really take off—literally! From concept (how to get medical supplies to remote areas without roads), to design, to manufacturing, to a finished Quadcopter flying across the conference stage carrying a package, this demonstration brought it all home to the audience. Collaborating with each other on the **3DEXPERIENCE** platform, the team of SIMULIA analysts used Abaqus/CAE, Abaqus/CFD, fe-safe, Tosca, Simpoe Mold, Isight and more to prove out a reliable, robust aerial vehicle.

### **GETTING DOWN TO EARTH WITH BACKHOE DESIGN**

Going from the skies to the ground, our final example is the excavator, which some of you may remember from one of the General Lectures at the SCC. This complex, hardworking piece of industrial equipment presented an ideal opportunity for highlighting the diverse capabilities of the SIMULIA Portfolio.

CATIA Systems' Dymola, Abaqus, XFEM, CEL and Tosca were all employed to answer various questions about the backhoe's performance, durability and structural integrity—and reduce weight by 20%.

### **BRINGING THE POWER OF THE PORTFOLIO HOME**

I hope these examples help you visualize how you might be able to take full advantage of SIMULIA technologies. Whatever your current work description, we can help identify which tools will help you explore every challenge and arrive at solutions that are as complete as possible. In the complex world of design engineering, the appropriate solvers can spark discovery into the deepest levels of physical phenomena inherent in a vast variety of products.

We have seen the power of the SIMULIA Portfolio in action with our customers and know that as you grow your expertise to include more of our products, you will see the benefits yourself. So when it next comes time for your team to renew the SIMULIA products that you use, please think about trying the Power of the Portfolio through the Extended Token Program. You'll easily experience how access to Abaqus, Isight, Tosca and fe-safe can expand your impact, enrich your professional capabilities and keep you current with all that software technology can provide. The job of the analyst is rapidly changing. We're here to help make sure you have what you need to succeed.

### **CONSISTENT RELEASE NUMBERING IS COMING SOON**

Expansion of the SIMULIA Portfolio through acquisitions has made more technologies readily available, but also created a need to rationalize release numbering. To make it easier to identify releases that work together, in the summer of 2015 SIMULIA plans to roll out a new and consistent release numbering system for Abaqus, Isight, Tosca & fe-safe. Following Dassault Systèmes corporate practices, SIMULIA releases will carry the number of the calendar year of the release *plus one*.

There will be no releases numbered Abaqus 6.15, Isight 5.10, Tosca Structure 8.2, Tosca Fluid 2.5 or fe-safe 6.6. Releases for all of these programs will be consolidated under the new numbering system. The following deliveries scheduled for the summer of 2015, will be identified as release "2016": Abaqus 2016, Isight 2016, Tosca Structure 2016, Tosca Fluid 2016, fe-safe 2016. This change should eliminate questions such as, "What release of fe-safe works with Abaqus 6.14?"

Customers may begin to notice the change sooner, for example a bug report might say, "The issue will be fixed in "Abaqus 2016.""

**For More Information**  
[www.3ds.com/SCN-September2014](http://www.3ds.com/SCN-September2014)

# Cover Story

## TUNNEL VISION

Dr. Sauer and Partners helps upgrade London Underground station



As population pressures in metropolitan areas rise, major world cities often respond with expanding networks of trains to promote more efficient travel. The London Underground is no exception: it now serves Greater London and surrounding counties with 270 stations and 250 miles of track. Some 1.23 billion passengers were carried in and out of the region in 2012/2013.

At the geographic heart of this system are the world's first underground railway tunnels, opened in 1863 and built just below the surface of metropolitan London using the cut and cover method. Later, circular tunnels—giving rise to the nickname the Tube—were dug through the London Clay at a deeper level.

Now celebrating 150 years of operations, the Underground is still growing: The current Bond Street Station Upgrade (BSSU) project, slated for completion in 2018, has been dubbed "one of the most complex tunneling projects in the U.K." As London's future Crossrail line intersects with the Bond Street Station, passenger numbers in the expanded interchange are expected to rise from 155,000 to 225,000 daily.

Much of what makes the BSSU so complex is all the construction that is already there. The station is located in London's busiest shopping district, the West End, and comprises a complex web of train tunnels, pedestrian walkways and escalators that include connections to the Jubilee and Central lines. "The new tunnels are located in close proximity to so many existing ones," says Dr. Ali Nasekhian, senior tunnel/geotechnical engineer with Dr. Sauer and Partners, London,

the firm providing tunneling expertise to the project. "As a result, the design challenges we faced included complex tunnel geometry and alignment, limited clearance to existing building foundation, restricted worksite and strict settlement criteria."

Dr. Sauer and Partners have been designing railway and road tunnels for over 30 years. In 2010 the company was subcontracted to a joint venture of Halcrow and Atkins (the main contractor is a Costain Laing O'Rourke JV), and has responsibility for preliminary-to-detailed design and construction on all BSSU sprayed concrete lined (SCL) tunnels. These include two access shafts, one lift shaft, four construction adits (entrance passages), two binocular cross passage tunnels, four large concourse and connection chambers, three underpass tunnels, two over-bridge tunnels cutting through existing platform tunnels, two niches for electrical and mechanical equipment and four inclined tunnels for escalator barrels. The total length of tunnels, at widths varying between four and 10 meters, amounts to some 450 meters.

**"The confidence we have gained from our analyses has helped us push forward the approval process more vigorously and is providing the highest quality of robust design to our clients."**

—Ali Nasekhian, senior tunnel/geotechnical engineer,  
Dr. Sauer and Partners



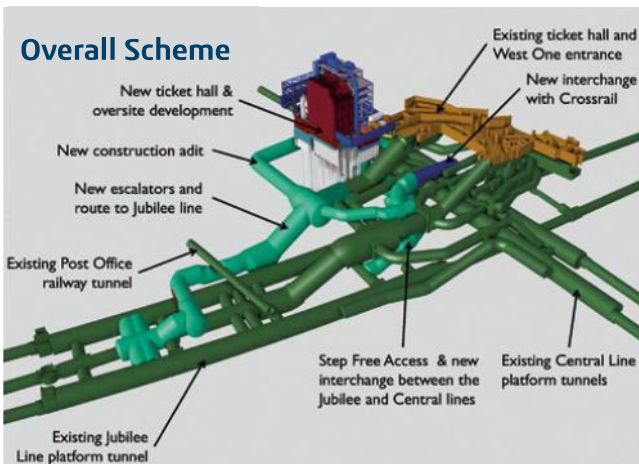

The complexity of the Bond Street Station Upgrade can be seen in this diagram of the overall scheme of upgrade. Existing tunnels are in dark green, while new construction designed and being installed by Dr. Sauer and Partners is in lighter green.

Dr. Nasekhian came on board at Dr. Sauer in 2011 after finishing his Ph.D. in geotechnics at Graz University of Technology, Austria, and his eight years' experience with computer-aided design was immediately put to work.

"In such projects as the London Underground, where large tube systems are already in place and the impact of new structures on existing ones has to be carefully considered, comprehensive 3D analysis benefits both client and designer," he says. "In addition to 2D analyses, where time and budgets allow, 3D models can greatly assist in identifying the optimum design."

The Dr. Sauer design team of eight engineers used Abaqus finite element analysis (FEA) software to perform all 3D numerical analyses ahead of the main tunneling works. (Tunnel excavation began in the summer of 2013, with completion scheduled for 2015.) Dr. Sauer & Partners have employed Abaqus since the 1990s.

"We find the Abaqus solver to be very powerful, stable and speedy for plastic analysis of models with large numbers of elements," says Dr. Nasekhian, who led the FEA modeling effort. "It is well recognized that the quality of FE models is largely dependent on the quality of the mesh. Of course, finer meshes require a larger number of elements. I myself had not used Abaqus before joining the Dr. Sauer team, and I found that pre- and post-processing, and creating and manipulating large, complex geometries, is amazing with this software."

"If any changes need to be made in the geometry, which often happens when you are creating the most efficient design, Abaqus lets you modify them fairly rapidly. Such handy tools available in Abaqus/CAE reduce the risk of delay in delivering large 3D FE models."

For the geometric foundation of their FEA models, the team first considered importing existing CAD models of the station complex from another type of software. But conversion and

meshing issues would have added extra work. "We preferred to create our own working geometries right within Abaqus/CAE," says Dr. Nasekhian. "This enabled us to modify the geometries easily if we had meshing issues."

In the preliminary design stage, the team conducted a series of 2D analyses to establish the varying dimensions of tunnels required along the different structures. Once the tunnel geometries were "frozen" in final form, the creation of the 3D models could begin.

For a realistic assessment of the stresses and strains imposed by the surrounding soil layers, the ground through which the tunnels are being dug was simulated alongside the tunnel structures. Including the subsurface geology of the London basin—layers of Chalk, Thanet Sand, London Clay, River Terrace deposits and "made ground" from hundreds of years of human occupation—provided for soil-structure interaction analysis.

The majority of the new BSSU tunnels are located within the London Clay stratum, which has a very low permeability. The conventional method of tunneling known internationally as NATM (the New Austrian Tunneling Method), is being used. In the U.S. this is called SEM (Sequential Excavation Method) and, in the U.K., the aforementioned SCL (Sprayed Concrete Lining) method.

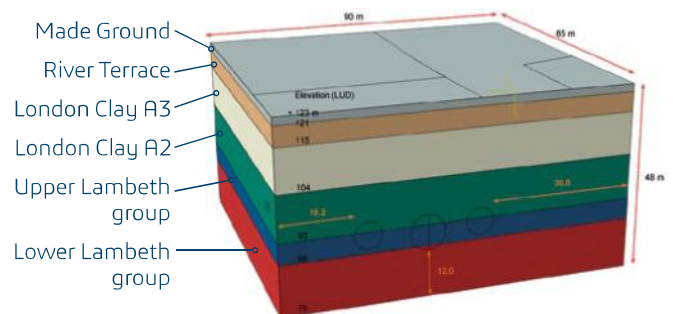

Subsurface soil stratification of the London basin. Most of the new Bond Street Station tunnels run through the London Clay stratum, with between five and 25m of overburden. A geostatic stress field based on this geology is set up as initial stress state from which ongoing tunnel excavations and the resulting deformations are simulated.

In the SCL method, the tunnel is divided into several excavation sequences; after each sequence, sprayed steel-fiber-reinforced concrete (primary lining) is applied to the exposed ground with robotic sprayers, rapidly stabilizing it. When excavation of the whole tunnel is completed and deformations of the primary lining become stable, sprayed waterproofing membrane is applied. This is followed by a final secondary lining of steel-fiber-reinforced concrete for a fully water-tight tunnel. At tunnel junctions, steel rebar reinforcement is employed as needed to further support areas under severe flexure and tensile stresses.

The major construction sequences (i.e., step-by-step excavation and lining installation) were incorporated into the Abaqus FEA models to provide the engineers with insights into the

# Cover Story

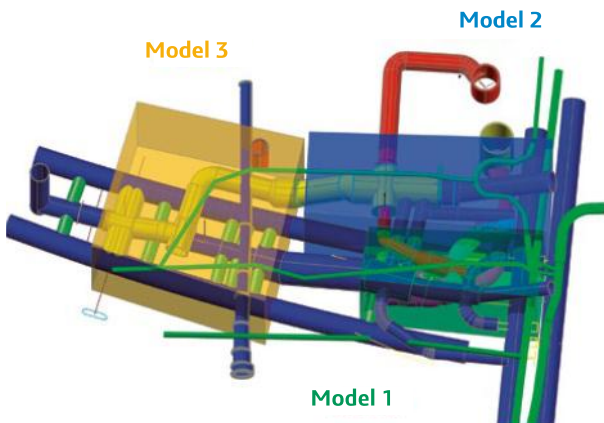

Dr. Sauer and Partners design engineers divided the BSSU project into three separate models to simplify the huge analysis and simulation task. Where existing structures were extremely close, models were allowed to overlap.

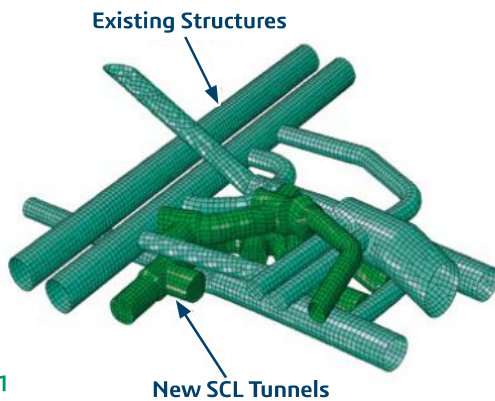

Model 1

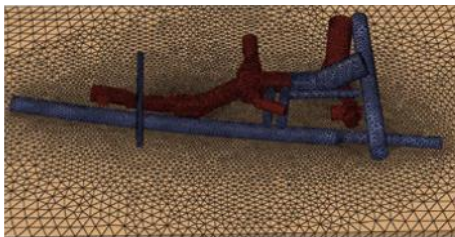

Model 2

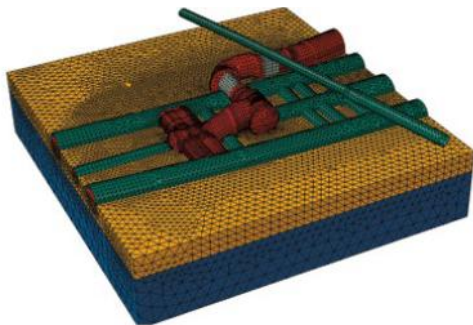

Model 3

(Models 1-3). The three separate Abaqus FE model meshes created by Dr. Sauer and Partners for the London Underground tunnel project.

influence of each construction stage on the new tunnel linings and the adjacent assets. To improve their computational efficiency, the team divided the labyrinth of existing and proposed BSSU structures into three separate models that varied in number of elements from about 450,000 up to one million. "We selected the limit between two adjacent models in places where the distance between the closest two tunnels on either side of the models is more than three times the diameter of the larger tunnel," says Dr. Nasekhian. "In very congested tunneling areas where this condition couldn't be met, we modeled a couple of tunnels by overlapping two of the models."

Dr. Sauer and Partner's Abaqus analyses provided them with:

- A good estimate of ground movement and volume loss during tunnel construction, including identifying trigger values beyond which a ground-movement management plan would be implemented. "In this kind of project," says Dr. Nasekhian, "it's important to have realistic values in hand so tunnels aren't constructed in an overly conservative manner, which can be cost-ineffective."
- An evaluation of the stress being induced in the adjacent existing structures while tunneling was taking place. Deformations in the FE model were initially set at zero and then propagated with ongoing excavation steps.
- Dimensioning the new SCL tunnels and a basis for calculation of necessary reinforcements, especially at locations of stress concentration. "The results of our 3D simulations were particularly helpful for optimizing SCL design at tunnel junctions, which helped avoid a great deal of rebar installation," says Dr. Nasekhian.
- Assurance of face stability during excavation.

The Sauer design team found that realistic simulation with 3D modeling gave them a deeper understanding of the many BSSU tunneling challenges and helped them reach the best design and construction solutions.

"In this very complex project, our Abaqus models helped improve our preliminary design, which was based on series of 2D analyses and the design team's experience, and led us to an extremely well-detailed final design," says Dr. Nasekhian. "The ease of working with Abaqus allowed us to develop a number of techniques that improved simulation fidelity and saved time when running such large models. The confidence we have gained from our analyses has helped us push forward the approval process more vigorously and is providing the highest quality of robust design to our clients."

## For More Information

[www.dr-sauer.com](http://www.dr-sauer.com)

## SIMPACK JOINS THE DASSAULT SYSTÈMES FAMILY

This summer, SIMPACK became part of the Dassault Systèmes family, a move that expands the SIMULIA realistic multiphysics simulation technology portfolio to include multibody mechatronic systems, from virtual concept validation to the real-time experience.

“The acquisition of SIMPACK, part of a larger, ongoing strategy to continually expand the **3DEXPERIENCE** platform, enables a complete virtual and real product experience, like never before,” says Bernard Charlès, President and CEO, Dassault Systèmes. “Consumers expect automobiles, aircraft and nearly all products to continually get smarter, safer, faster, quieter and more efficient. This means companies need to do more than engineer everything coming together—such as controls, movement, bending and noise. They need to experience their product as they create it.”

Founded in 1993 (as INTEC at that time, a spin-off from DLR, the German Aerospace Center), SIMPACK has demonstrated strong technology leadership, in particular through complex models, nonlinear effects such as friction and flexible structures, efficient numerical algorithms and real-time capabilities. With SIMPACK technologies enhancing the **3DEXPERIENCE** platform, Dassault Systèmes will provide the leading integrated solution for end-to-end development of advanced systems, combining realistic multiphysics simulation, accurate real-time simulation of mechatronic assemblies and control of smart systems.

“We have similar technology-driven cultures and a shared long-term commitment to scientific excellence,” says Alex Eichberger, Founder and CEO, SIMPACK. “We will join forces and technologies to provide superior virtual and physical experiences, expanding industry solution experiences for Transportation & Mobility, Aerospace & Defense and other industries.”

The SIMPACK acquisition is the next step in the growth of the SIMULIA brand, delivering on the company’s commitment to provide the highest quality comprehensive solution for realistic simulation across all industries, says SIMULIA CEO Scott Berkey.

### WHAT DOES SIMPACK DO?



SIMPACK is a leading provider of multibody simulation software, which is used for the dynamic analysis of any mechanical or mechatronic system. It enables engineers to generate and solve virtual 3D models in order to predict and visualize motion, coupling forces and stresses. With its headquarters in Germany, SIMPACK also has offices in France, Great Britain, Japan and the United States and partner offices in Brazil, China, India, Turkey and the Republic of Korea.

Learn more about SIMPACK at [www.SIMPACK.com](http://www.SIMPACK.com).

Each acquisition over the past few years has helped SIMULIA strengthen our brand and expand our technology foundation. The SIMPACK technology substantially extends our solution early into the concept phase and will allow us to provide a truly integrated solution spanning conceptual engineering through validation, with advanced nonlinear performance capable of providing a realistic, real-time virtual experience of the performance of mechanical and mechatronic “systems,” Berkey says.

For existing customers, no immediate changes are expected. Users will still be able to access SIMPACK on a standalone basis tailored to their individual needs and, in the near future, as part of the SIMULIA Portfolio. We will be supporting our customers with the same people you know, as well as service levels and commitment to innovation you have come to expect. In time, we’ll introduce new products, including variations using SIMPACK technology that are more integrated in the overall engineering solution.

### For More Information

[www.3ds.com/SCN-September2014](http://www.3ds.com/SCN-September2014)

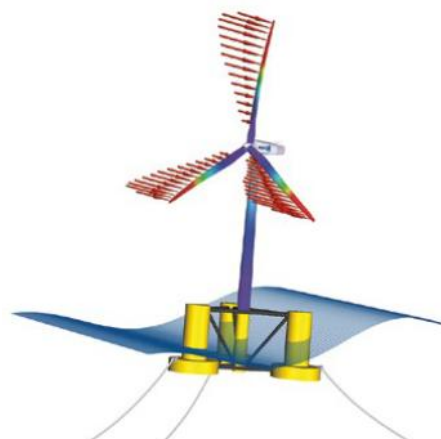
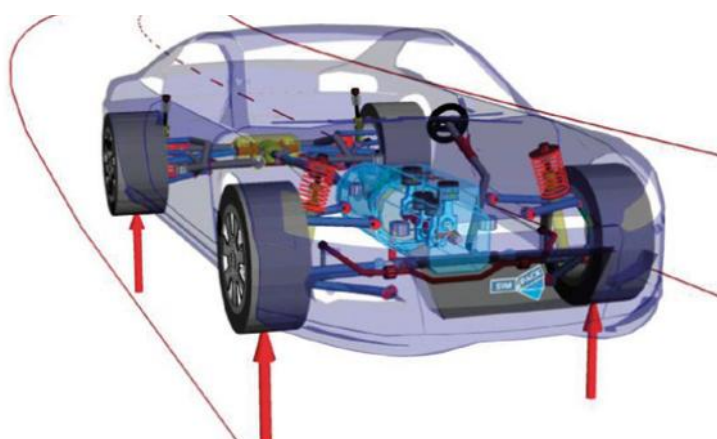



## Case Study

### STADLER RAIL SIMULATES TRAIN SAFETY WITH FEA

Rail car design company uses Abaqus software to improve crashworthiness



In the early 20th century, a strange spectator sport flourished in America: train crashing. They were so popular that one man, Joe “Head-on” Connolly, staged 73 crashes (destroying 146 trains) between 1896 and 1932 at state fairs and other large venues.

Those days are long gone. Engineers (the design kind, not the train-drivers) who want to observe a crash can run perfectly safe, highly accurate virtual collisions on a computer screen.

While designing a new rail car, the engineers have a significant need for simulation in order to best address safety questions. In the event of a crash will the welds hold, particularly if the train is in its later years of service? Will the passenger portion of the coach retain its shape? Also important: Will the internal components and assemblies of the passenger area remain in place and be relatively undeformed?

Stadler Rail, headquartered in Bussnang, Switzerland, has been answering these questions (with and without simulation) for over 70 years. In the process, they’ve designed and built tailor-made trains, regional, tram, meter-gauge and even bi-level trains. In recent years, they put that expertise to work designing a double-decker commuter train, the KISS (KISS is a German acronym that means “comfortable innovative speedy suburban train”). The train runs at speeds up to 200 km/hr. (124+ mph) and is a workhorse for train lines in Switzerland and Austria.

As with all transportation designs, keeping weight light is an important goal. (“Light weight” is relative—each six-car train weighs 297 tons. To ensure strength at the same time, the car body is made from 35 hollow, large-scale aluminum extrusions joined with an incredible number of MIG welds. Friction stir welds are applied for the intermediate floor. “There are about 12,000 meters of welds in a railcar,” says Dr. Alois Starlinger, Head of Structural Analysis, Testing,

and Vehicle Authorization at Stadler Rail. “Under those circumstances, weld performance is every bit as vital for safety as that of the extrusions themselves.”

Crash Energy Management, or CEM, is an extensive part of product development for a new train design. It is guided by a number of different European rail safety standards, most notably “Crashworthiness requirements for railway vehicle bodies (EN 1527).” A significant portion of those standards defines what portions of a design should be proven out with simulation and how to do it.

Central to that process at Stadler is Abaqus, the finite element analysis (FEA) application from SIMULIA, the Dassault Systèmes **3DEXPERIENCE** technology. “Stadler has used Abaqus for over 10 years for these sorts of simulations,” Dr. Starlinger says.

#### MAKING A MODEL

When Stadler first began using Abaqus, FEA models in general were far more narrow in what they could analyze. A decade of advances in computing hardware and software has led to the current generation of extremely detailed yet highly efficient models. The KISS railcar model used over 3 million elements and had 12 million degrees of freedom (Figure 1). A typical element length represented just 25 millimeters of the 25-meter car, affording a close-up look at load effects throughout. The aluminum extrusions, welds, milled

**“Abaqus enabled us to reduce product development times for the KISS cars while retaining high quality and safety.”**

—Dr. Alois Starlinger, Head of Structural Analysis, Testing and Vehicle Authorization, Stadler Rail

parts, and even fasteners (over 1000 bolts and rivets) are represented. "We paid special attention to defining element density and mesh quality," Dr. Starlinger says, "in order to fully optimize the simulation's capture of stress gradients."

The model was used for static analyses, in Abaqus/Standard, of 45 different global load cases examining the passenger area, the car coupler, and buckling and vibration modes. An important goal was to check whether the car design would withstand the given load conditions or would deform unacceptably. "The largest effort for development and certification of the KISS train was the stage of calculating and evaluating these load cases," says Dr. Starlinger.

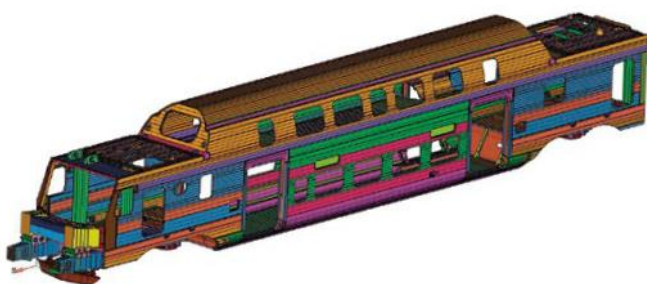

Figure 1: Overall FE-model of the KISS train bi-level car body

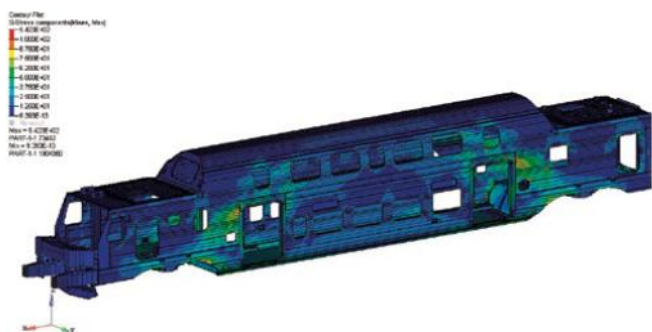

Figure 2: Stress results for the load case: coupler compression 1500 kN

The most important case was an impact load of 1500 kN on the coupler joining the rail cars. It was specified by a safety standard (EN 12663-1) that states the railcar must sustain such an impact with minimal deformation. Running their analysis, Stadler engineers found little to no deformation in the coupler, and the other static analyses were positive as well (Figure 2).

### FIGHTING FATIGUE

Once the static analysis was complete, engineers evaluated the Abaqus FEA results using the fatigue strength postprocessor FEMFAT from Magna. Fatigue loads for weld examination included damper forces between the car body and the bogie (the wheel, axle and frame assembly, often called a "truck" in the U.S.), traction and braking loads and acceleration loads in all major directions. "Fatigue effect on the welds is quite important," Dr. Starlinger says, "since the aluminum welds

have a lower fatigue strength than the base materials of the extrusions building the car body." Fatigue stretch data were drawn from the International Institute of Welding (IIW) recommendations and the German FKM guideline.

"We used the notch-stress approach for the fatigue evaluation," Dr. Starlinger says. "It gave us insight into the life of the most critical part of the weld for all load cases." The fatigue software cycled the welds through the projected 40-year operating conditions and lifespan of the railcar, providing the load collective (total load of the car), along with specifics about notch-weld stresses. "The static and fatigue analyses we made gave us a high degree of confidence in how the car would perform," Dr. Starlinger says.

But some large questions remained: How would the individual features of the car—in particular, the crash module—perform in the event of an impact?

### COMBATTING CRASH

Four standard collision scenarios require examination of impact: front-end with an identical train unit, front-end into a buffered rail vehicle, front-end into a heavy obstacle (such as a truck at a road crossing), and impact into a low obstacle on the track. Of all these the most critical is the head-on impact between identical railcars, since it could potentially cause the highest number of injuries as well as the most serious ones. "We performed dynamic crash analyses using Abaqus/Explicit," says Dr. Starlinger, "on a time line extending from the first collision contact until 0.2 seconds after the impact."

The analysis focused on the crash module at the front end of the car (Figure 3). This module, a tapered tube with multiple chambers, is designed to absorb energy by plastic buckling sequentially (and predictably) on impact, contributing to the rest of the car retaining its shape and protecting any occupants. The simulation involved materials characteristics and behavior under crash load as well as the deformation of the module. "We've been analyzing railcars with Abaqus for more than a decade," Starlinger says, "and we have extensive physical test data to use along with the results of previous simulations."

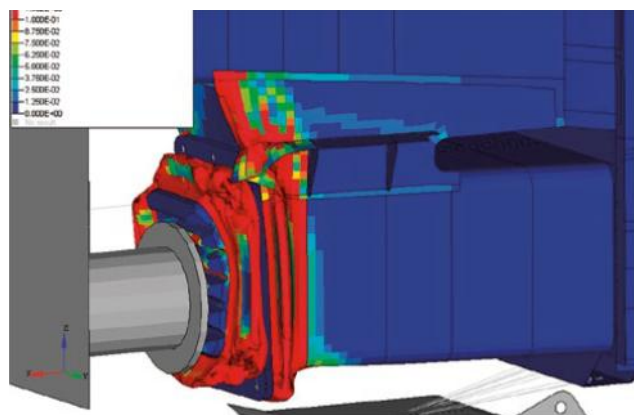

Figure 3: KISS car body model for collision simulations – Results for plastic strain



# Case Study



Figure 4: Full-size railcar body set up for static testing

## VIEWING VALIDATION

Physical prototyping and testing remain an important part of railcar design. While simulation provides valuable insights into design and helps engineers meet safety standards, there are additional requirements for validation of static and dynamic analyses through physical testing. Tests include applying vertical and longitudinal loads to railcar structures and using hydraulic actuators.

During real-world testing of the KISS car, the main deformations of the full-size railcar body and components were measured and stress levels obtained at over 140 positions via strain gauges. The physical testing showed a close correlation with the FE analyses, and dynamic loading of the crash module also produced results in close agreement with the simulation (Figures 4 and 5).

## INTERIOR AND EQUIPMENT STRUCTURES

Interior components and equipment were also evaluated in accordance with safety standards. These included a detailed examination of such items as staircases, seats, toilets, luggage racks, internal doors, and the driver's seat and desk. In the stair area, for example, the engineers included passenger mass and specific forces at the hand-rails in their analyses.

Among the nonlinear phenomena analyzed was behavior of the cantilever beam that fixes a passenger seat to the railcar wall. The engineers modeled the different welded, milled, and forged pieces of the assembly to capture as complete an understanding of the seat beam as possible. Analysis results determined the potential displacement of the seat structure under impact loads, information that provided basic data for defining bolt quality as well as assembly parameters.

Outside of crash analysis, the engineers looked at vibration of key train components during normal operation—for example, a simulation of the constant vibration created by the rotating mass of the compressor engine. This analysis applied a dynamic force within a specific frequency spectrum and explored the effects of fatigue on features of the railcar.

## RESULTS ON THE RAILS

Stadler's simulations confirmed that the KISS railcar design successfully fulfilled all requirements of the European standards. Over 170 multilevel car trains have been ordered, many of which are already in service in Switzerland, Austria, Germany and Luxembourg.

"Abaqus enabled us to reduce product development times for the KISS cars while retaining high quality and safety," Starlinger said. "We were able to quickly perform a significant number of analysis iterations, enabling us to optimize the railcar structure in terms of weight while still meeting all safety standards. That helped Stadler to meet its stringent time schedule for structural design releases. Up to now, Stadler has kept all contractual deadlines for product delivery to the customer."

## For More Information

[www.stadlerrail.com](http://www.stadlerrail.com)

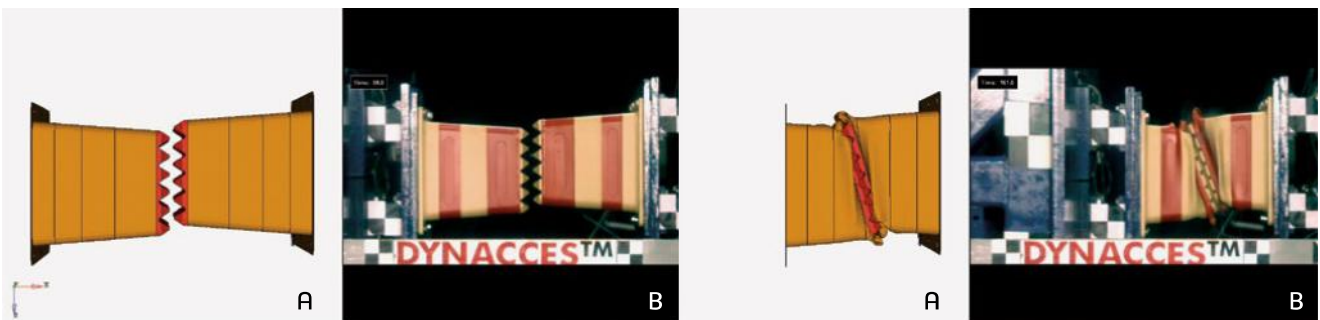

Figure 5: Validation of dynamic test of the crash module – comparison of deformation in simulation (A) and physical testing (B)



## TOPOLOGY AND SHAPE OPTIMIZATION USING THE TOSCA-ANSA ENVIRONMENT

**B**ETA CAE Systems S.A. is a private engineering software company committed to the development of state of the art CAE software systems that meet the requirements of all simulation disciplines. Committed to its mission to produce best-in-class CAE software systems, BETA CAE Systems offers products that consistently exceed expectations and provides exemplary technical support to its customers.

The company's products, the ANSA /  $\mu$ ETA pre- & post-processing suite and SPDRM, the simulation-process-data-and-resources manager, holds a worldwide leading position across a range of industries, including automotive, railway vehicles, aerospace, motorsports, chemical processes engineering, energy, electronics, heavy machinery, power tools and biomechanics.

Nowadays, manufacturers need to design and produce reliable but still lightweighting and elegant components, at minimum cost. Fortunately, the computational resources are continuously growing, offering new perspectives for optimum designs, within reasonable time periods. Due to the remarkable reduction in the development time of simulation analysis, it is possible to define, quite quickly and precisely, the necessary modifications on a part's shape. The final aim is to reduce the total mass, while keeping stresses at an acceptable level.

This can be easily and robustly achieved through the Tosca-ANSA Environment (TAE), which provides a complete interface for Tosca, powered by the ANSA Task Manager and other ANSA features. This interface facilitates the definition of Topology, Shape, Bead, and Sizing optimization problems, providing feature based entries for all Tosca Structure keywords. It

continuously checks the consistency of the optimization models and helps the completion of the optimizations problem setup. TAE allows the set-up of the optimization parameters (design space, frozen areas, manufacturing constraints, etc.) through the Graphics User Interface of ANSA. It also provides the monitoring of the optimization steps within the same interface, through the VTF Visualization module of Tosca.

As an example, Figure 1 depicts the result of the Topology and Shape optimization process for a drilled Brake Disc. The inner disc that connects the wheel with the outer Disc (braking surface), is the area that has been optimized (Design Area).

The Topology algorithm recognized the unstressed areas and gradually removed material. The result was an elegant component that fulfills the shape and operating needs. As expected, the new component was more evenly stressed. However, after the material reduction, there were still some stress concentrations. For this reason a Shape Optimization followed. Within a few iterations, the stress concentrations were reduced and the peaks were minimized by shortly moving the appropriate nodes.

Using the automated process of Tosca-ANSA Environment, it was possible to reach a component's optimum design proposal in an impressively short period of time keeping only 40% of the initial volume, and maintaining the maximum stress.

The duration of such a process is dependent on the time used for solving since the optimization algorithms run rapidly.

**For More Information**  
[www.beta-cae.gr](http://www.beta-cae.gr)

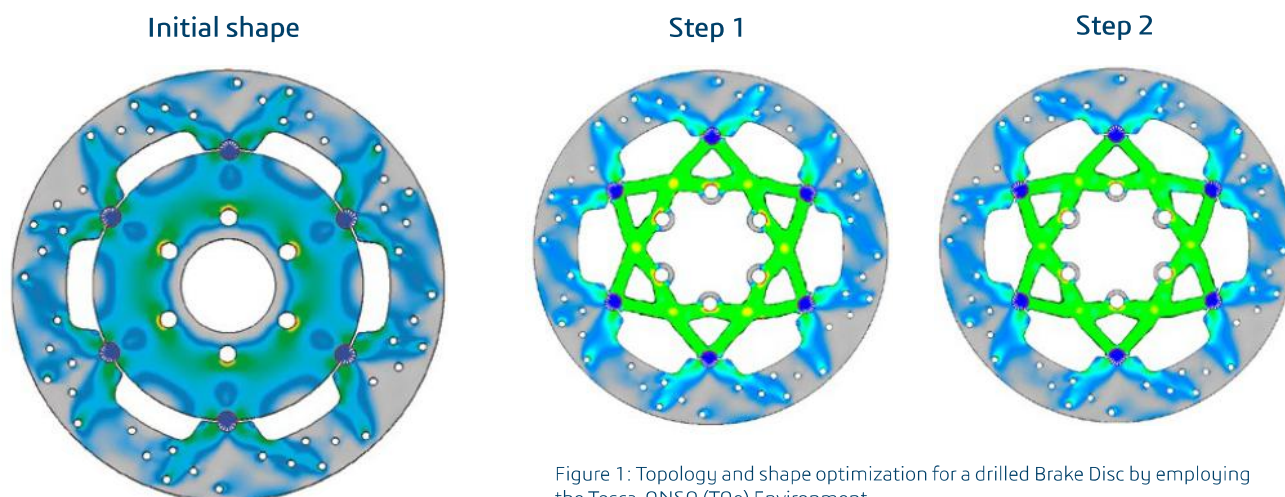

Figure 1: Topology and shape optimization for a drilled Brake Disc by employing the Tosca-ANSA (TAE) Environment.

## Case Study



### FINE-TUNING THE ANATOMY OF CAR-SEAT COMFORT

New muscle detail in Wölfel's 3D human-body model gives realistic simulations more accurate predictive power as the field evolves

Although driving a car is done sitting down, feeling physically tired after a long car ride is no accident: While navigating busy city streets, curvy country roads, or even slow-moving commuter traffic, drivers are in an almost constant state of motion, pushing and releasing the vehicle's pedals to accelerate, brake or clutch.

Legs and feet change position: as the ankle flexes, the lower leg extends and retracts, and the muscles in the thigh and buttocks contract and relax. Since the thigh muscles are in constant use, it follows that the seat design—especially the front of the pad that supports the thigh—will be important when determining driver comfort.

"Even holding the accelerator pedal at a desired position requires constant muscle activation," says Alexander Siefert, manager of Seating Comfort and Biomechanics at Wölfel Group—a German-based company specializing in engineering services and related testing systems for the design and development of car seats. "This alters the stiffness of the muscles involved. It also has a significant effect on seat-pressure distribution and stress/strain values within the tissue, which are important measures of seat comfort."

Engineers on Wölfel's Seating Comfort and Biomechanics team know what they're talking about. Their finite-element model CASIMIR helped set current German occupational and health standards (vibration and shock) for working drivers of vehicles such as trucks, taxis, buses, and construction equipment. As human-body modeling rapidly evolves, Wölfel has turned to the issue of comfort with both commercial and passenger vehicles in mind.

#### SIMULIA SOLUTIONS FINE-TUNE COMFORT

Longtime users of SIMULIA Abaqus finite element analysis (FEA) software from Dassault Systèmes, The 3DEXPERIENCE Company, Wölfel has enhanced CASIMIR to include models that make their digital-driving simulations even closer approximations of real-world conditions.

"We have high confidence in our Abaqus analyses because of the software's advanced non-linear and contact capabilities," says Siefert. "Its material models for seat foam and human tissue are extremely useful when conducting human-body simulations for car seats."

Wölfel has drawn on extensive medical imaging data (CT scans, MRI cross-sections, and dissection photographs) from the U.S. National Library of Medicine's (NLM) Visible Human project to more accurately model the soft tissues, and especially the muscles, of the body parts that either contact the seat or are important in sitting. [see SIMULIA Insights Sept./Oct. 2010 pp. 20-22: <http://www.3ds.com/fileadmin/PRODUCTS/SIMULIA/PDF/case-study/SIMULIA-Wolfel.pdf>].

Recently, they refined their simulations to represent the intricacies of muscles in motion, developing a method that couples two models: a volumetric model representing passive nonlinear muscle behavior; and a filamentary model representing the active muscle force required to either maintain posture or make the movements, such as pedal operation, that are necessary for driving. By coupling the two models it can be demonstrated that the passive volume stiffens when the filamentary model is activated.

Pursuing this strategy, the team performed simulations for driving studies in which muscle activation was accounted for. In one study, they validated muscle activity in the abdomen and back for use in upright-seating-posture studies. In another, they analyzed the thigh and buttocks and began to understand the importance of pedal operation on seat comfort.

**"Simulating comfort using FEA greatly simplifies the process. It's objective, reproducible and cost-effective."**

—Alexander Siefert, Wölfel Group

Looking to increase the robustness of these types of active-muscle simulations, the team decided that additional enhancements and studies were required.

### VALIDATING THE COUPLED-MODEL APPROACH IN A SINGLE ISOLATED MUSCLE

To further prove out the concept and benefits of coupling the volumetric and filamentary muscle models, the team decided first to simulate an imaginary muscle outside of their CASIMIR software. After setting up simulations of different loads on the volumetric model and different states of muscle contraction on the filamentary model, the engineers used the embedded element option in Abaqus to generate a kinematic relationship between the two. In an experimental set-up designed to demonstrate the real-world veracity of this coupled scenario, measurements were made after an indenter mass of five different weights was lowered onto a sample calf muscle (from a rat) to mimic muscle contraction. The team observed that the upper muscle volume in the calf lifted up in both the coupled simulation and the real-muscle experiment.

“We’re still fine-tuning our simulations so that they’ll even more closely correspond to measurements,” notes Siefert. “But after our study validated the coupled-model method in the isolated muscle, we wanted to show it would work in the full body-model.”

### VALIDATING THE COUPLED APPROACH IN CASIMIR

To prepare the full-body model for a similar coupled analysis, the separate thigh and buttocks models needed to be further enhanced. High-contrast photos from NLM were especially useful in achieving more accurate muscle volumes; whole-body MRI scans in the prone and supine positions (from another source) provided additional detail as well. In the volumetric thigh model, smaller muscles were assembled into one volume to simplify the calculation. For the filamentary model, the team first focused on the hamstrings (flexor), since that is the muscle group that contacts the seat and is activated during driving.

CASIMIR’s thigh and buttocks were then placed on a cuboidal piece of foam representative of a car seat. The model was loaded for its own weight, as well as with the hamstrings

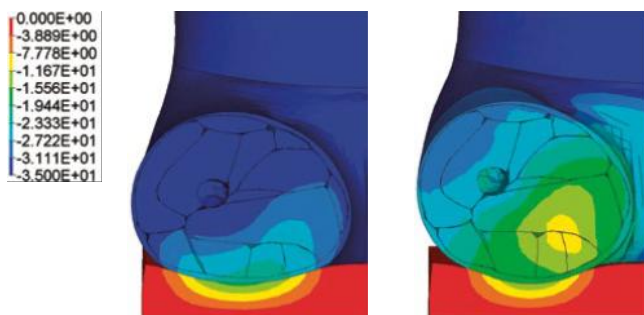

Figure 1. Abaqus FEA graphics of the thigh muscles (shown in cross-section) illustrate vertical displacement for gravity loading only (left) and with the hamstrings activated (right).

activated. When the team compared calculations from this set-up with actual measurements from test subjects, the gravity-loaded scenario results were in close agreement (there was lateral expansion of the full thigh and movement between the muscle volumes). For the muscle contraction case, the vertical displacement (lifting up) of the leg also matched expectations (see Figure 1).

Finally, it was time to try out CASIMIR’s full-body model on a seat-pressure distribution scenario with muscle activation. The team explored a number of different loads including gravity and then knee flexion with resulting heel forces. Simulation and test results were in close enough agreement to validate coupling of the muscle models in future full-body-model simulations.

### WHAT’S NEXT FOR CASIMIR

Now that CASIMIR is capable of simulating not only passive reactions of tissue to external forces but also active muscle contractions, Wölfel can offer its customers the most sophisticated seat-design and driving-comfort guidelines to date. According to Andreas Nuber, assistant manager for research and development, the Wölfel team envisions a number of next steps to further increase the model’s capabilities.

For one, they would like to more fully validate other muscle groups, besides the thigh/buttocks, with measurements on test subjects. They are also busy improving muscle-tissue modeling to more realistically represent contraction dynamics, as well as vertebral-disc characterization to accurately predict loading on the lumbar spine.

Other high-level seating-comfort initiatives are under way as well: The team has conducted first tests using Isight (Dassault Systèmes SIMULIA’s time-saving process automation and optimization software) for the identification of seat-cushion viscoelastic-foam properties; they are also working with the developers of other body models, such as RAMSIS and AnyBody, (under the UDASim project funded by the German government) on data exchange formats to make a global seating-comfort analysis a possibility.

Wölfel’s research clearly benefits not only drivers, but the bottom line of car-seat suppliers and manufacturers everywhere. “Experimental seat-comfort studies have traditionally required many subjects and the testing of several hardware prototypes, all of which can be time consuming and expensive,” says Nuber. “Simulating comfort using FEA greatly simplifies the process. It’s objective, reproducible, and cost-effective. If we eliminate just a single hardware prototype during the design process, the savings can be as large as 50,000 €.”

### For More Information

[www.woelfel.de/en/](http://www.woelfel.de/en/)



### **OIL & GAS SUBSURFACE INNOVATION WITH MULTIPHYSICS SIMULATIONS**

Stanford researchers use Abaqus to explore the physics of petroleum reserves



Recent reports indicate that the United States is poised to become the biggest producer of oil & gas in the world, thanks in large part to extraction from shale rock resources. Alternative energy is gradually contributing more to the world's energy supply but, given current global demand, there will continue to be significant focus on the development of both conventional and unconventional oil & gas reserves for the foreseeable future.

With safety and efficiency of paramount importance, there is an urgent need to better understand the physics and the connection between oil & gas extraction practices—such as hydraulic fracturing and water reinjection—to seismic activity and production declines. Realistic multiphysics simulation of subsurface formations provides a powerful method to understand the behavior of oil & gas fields, both from production efficiency and safety points of view, over the entire lifecycle of the fields, from initial development to continued operations over years or even decades.

At Stanford University, Ph.D. candidates Jeremy Brown and Randi Jean Walters, under the guidance of Prof. Mark Zoback of the Stanford School of Earth Sciences, have been using Abaqus to understand and develop potential methods and solutions for some of these challenges. Brown and Walters are both working on their doctorates in geophysics in the Stress and Crustal Mechanics Group at Stanford. He holds an M.Sc. in geophysics from Stanford and a B.Sc. in geophysical engineering from the Colorado School of Mines. She also holds an M.S. in geophysics from Stanford and has a B.S. in geosciences from Boise State University with a minor in Applied Mathematics.

“Our group is working to better understand how changes in situ stress can lead to triggered and induced earthquakes, fault reactivation, wellbore stability issues when drilling, reservoir compaction and subsidence, and production from both conventional and unconventional reservoirs,” says Brown.

The Stanford Group works in collaboration with commercial oil & gas companies, which often provide the researchers with high-quality data from the field that can be used to better understand geomechanical processes. Brown specifically works with rock mechanics data from BP. The company acquires rock core when drilling into a reservoir and sends it to the Stanford lab for testing. Walters uses data provided by ExxonMobil that includes well-log information as well as injection, microseismic, and tilt data. She compares her Abaqus/CAE simulations of deformation to the real-world tilt data and microseismic event locations to determine whether her simulations are reasonable.

#### **SIMULATING STRESS PATHS OF RESERVOIR FAULTS**

Up to now there have been few geomechanical studies of Paleogene reservoirs in the Gulf of Mexico—studies that could help determine reservoirs' fault re-activation potential during initial depletion of the reservoirs or during subsequent re-pressurization of the reservoirs. Research into such scenarios could aid with optimal placement of wells and facilities or help to anticipate and prevent problems during production.

For such studies, Brown has adopted a multiphysics approach that couples a commercial reservoir simulator (for flow of the oil & gas) with Abaqus finite element simulations (for

geomechanics)—a scheme that allows the stress path taken at several production wells in a Paleogene-type field to be determined more accurately. The quantification of these nonlinear stress paths helps determine the potential for production-induced fault re-activation on reservoir boundary faults.

In recent work, Brown was able to determine that faults in the Paleogene are closest to failure at the initial stress state within the reservoir rather than during reservoir depletion. However, the simulations also indicated that failure is more likely during the re-pressurization phase of production—information that could allow operators to adopt appropriate mitigation strategies. Another interesting aspect of this study is that it was carried out using a streamlined workflow that allows efficient progression from structural and geologic modeling all the way to coupled multiphysics reservoir simulations, which lays the foundation for more thorough assessments based on probabilistic methods.



Jeremy Brown, Professor Mark Zoback and Randi Jean Walters

**“Abaqus is a powerful tool that has allowed me to do some great simulation work.”**

—Jeremy Brown, Ph.D. candidate, Stanford University

### **STUDYING DEFORMATION DUE TO STEAM INJECTION**

One of Walters’ research topics at Stanford uses Abaqus simulations to help understand how a heavy oil reservoir undergoing cyclic steam stimulation (CSS) responds to stress perturbations in the form of deformation. “Our insights could lead to a safer production environment, enhanced well casing integrity and improved production,” she says.

Walters collected borehole microseismic, surface tilt, and steam injection data at a heavy oil production site during the first instance of steam injection and, after spatial and temporal analyses, found a complex deformation environment. The goal of her ongoing research is to create a calibrated multiphysics simulation model that can first match the observed initial deformation patterns and then potentially predict future behavior as production continues.

Walters’ simplified Abaqus model, developed to simulate the subsurface deformation occurring as the result of steam injection at the pad, did not match the more complex deformation patterns, suggesting that a more-sophisticated model, incorporating various failure mechanisms, might be more appropriate. The failure models could be somewhat simplistic—such as homogenous inflation of the reservoir as if it were disk-shaped or a homogenous inflation of small disk shapes centered at the steam injection locations—or more complex, including the activation of shear slip on pre-existing natural fractures and hydraulic fracturing. “Advanced fracture and failure modeling and simulation capabilities in Abaqus will likely be critical in this research to understand the complex and evolving deformation patterns and their effects during CSS and other extraction methods,” says Walters.

### **ABAQUS HELPS SUPPORT SAFER AND MORE EFFICIENT OIL & GAS FIELD DEVELOPMENT**

Such research at Stanford and many other academic and commercial institutions worldwide, based on Abaqus multiphysics simulations, will continue to play a key role in contributing to safer and more efficient oil & gas field development and production operations.

“Abaqus is a powerful tool that has allowed me to do some great simulation work,” says Brown. “My research will hopefully provide some insight for oil and gas companies about the geomechanics in the Gulf of Mexico and will aid in better reservoir management. I am thankful to BP for providing financial support and technical guidance to allow me to do this exciting work.”

“SIMULIA’s software is clearly applicable to many different problem types,” says Walters. “The end goal of my research is to allow operators to limit the damage that occurs to their wells due to deformation in the reservoir and overburden as well as mitigate seismic hazard and risk. This work also provides an understanding of fluid propagation through the subsurface and how to identify that propagation via microseismic and deformation information.”

OnePetro.org (search for Abaqus for over 1,000 research papers) is a very useful resource for researchers interested in learning more about the use of multiphysics simulations in oil & gas.

#### **References:**

*Understanding Deformation Due to Steam Injection at a Heavy Oil Reservoir through Tilt Data, Microseismic Data, and Geomechanical Modeling.* Randi Jean Walters and Mark Zoback, Stanford Borehole Geophysics Laboratory.

*The Likelihood of Fault Re-activation in Paleogene Reservoirs: Depletion vs. Subsequent Injection.* Jeremy Brown and Mark Zoback, Stanford Stress and Geomechanics Group

**For More Information**  
<https://earth.stanford.edu/>

# Tips & Tricks

## OPTIMIZATION MODULE WITHIN ABAQUS/CAE

With Abaqus/CAE it is now possible to author, run and postprocess optimizations powered by the SIMULIA Tosca Structure technology. In this section you will find some helpful tips related to key functionalities of the Optimization Module.

### HOW TO SET UP AN OPTIMIZATION TASK TAKING MULTIPLE NONLINEAR LOAD SCENARIOS INTO ACCOUNT

The great power of Tosca optimization technology is its capability to find optimal designs for structures with nonlinear behavior. To achieve realistic and valuable optimization results it's necessary to consider all relevant critical load scenarios, which therefore have to be incorporated into a single optimization. The simulation of independent nonlinear load scenarios has to be done across multiple separate input decks instead of based on each other sequential STEP definitions in a single input deck.

#### Here's What You Do:

1. Create multiple copies of your model, containing the same geometrical data (mesh, section and material definitions, etc.) and in each copy define a specific nonlinear analysis step with its particular boundary conditions and loads.
2. Import all models in Abaqus/CAE. This makes all step definitions visible within a single Abaqus/CAE database and allows their use in one optimization setup.
3. Attached to one of the models, create an optimization task of the desired type (topology, sizing, or shape optimization).
4. Create several design responses, each associated with a particular nonlinear step inherited by the imported models.
5. All design responses are now available in the optimization tree and can be used in a single optimization as constraints or combined in an objective function.
6. When an optimization process is launched, the engine automatically submits all models in the database for analysis and extracts the structural responses of the different nonlinear load scenarios.

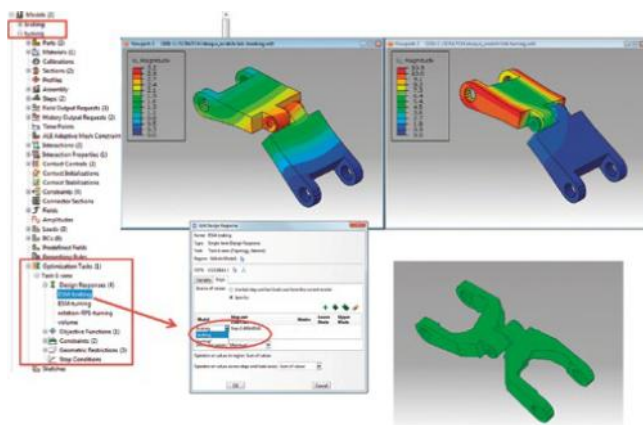

### UNIFIED APPROACH FOR GLOBAL STIFFNESS OPTIMIZATIONS

A common approach for global stiffness optimizations is to use the strain energy of the whole structure as a performance measure. However, the direction of the objective (minimize or maximize) depends on whether the deformations are force, displacement or thermally driven. In mixed scenarios selecting to minimize or maximize the strain energy does not guarantee a stiffer structure.

Tosca optimization technology now offers a unified measure, called "Energy Stiffness Measure" that can be used in all situations for sensitivity optimizations without having to differentiate between the deformation types.

#### Here's What You Do:

1. Create a design response of type **Energy stiffness measure** over **all elements**.
2. Always use in the objective function the target **minimize**.

### POSTPROCESSING OF OPTIMIZATION RESULTS IN ABAQUS/CAE

Two native Abaqus/CAE functionalities help to intuitively post process the results of Tosca Structure optimizations.

#### View Cut

When you open an output database from a topology optimization task you're usually interested in visualizing the optimized material distribution, called MAT\_PROP\_NORMALIZED. A View Cut based on the density isosurfaces is already automatically created and activated to hide areas where structural elements have relative densities below a defined threshold. Additionally, the animation of the optimization design cycles shows dynamically the redistribution of the material during the optimization process.

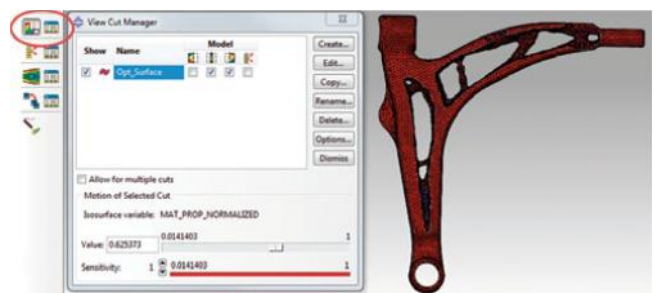

#### Link Viewports

Typically, the mechanical behavior of the original (reference) structure needs to be compared to the optimized design. Loading both models into two separate viewports and linking them enables synchronized motion and intelligible snapshots for comprehensive analysis of the results.

#### For More Information

[www.3ds.com/tosca](http://www.3ds.com/tosca)



*DON'T MISS OUT!*

# SIMULIA

## 2014 REGIONAL USER MEETINGS

SEPTEMBER–NOVEMBER 2014

Join us this fall at a RUM near you and hear the latest about SIMULIA from our executives, technical specialists and you!

- Corporate overview
- Product updates (Abaqus, Isight, Tosca, fe-safe)
- Customer presentations
- **3DEXPERIENCE**
- Networking opportunities
- Where SIMULIA is headed



**3DEXPERIENCE®**

<b>North America</b>	
September 23–24	Central
October 20–21	South
October 22–23	Great Lakes
October 29–30	West
<b>Latin America</b>	
October 14	Sao Paulo
October 16	Rio
<b>Europe/Middle East/South Africa</b>	
September 22–23	Nordic
September 26	Germany
October 15–16	France
November 4–5	United Kingdom
November 6–7	Benelux
November 6–7	Turkey
November 10–11	Austria
November 12	Spain
November 18	Israel
<b>Asia Pacific</b>	
September 16–17	Japan
September 18–19	Korea
October 17	India
October 20	Singapore
October 23	China

**REGISTER NOW OR LEARN MORE  
AT [WWW.3DS.COM/RUMS](http://WWW.3DS.COM/RUMS)**

# 2015 SIMULIA Community Conference

## THE LEADING SIMULATION EVENT OF THE YEAR!

InterContinental Hotel, Berlin, Germany  
May 18-21



Brandenburg Gate, Berlin

### NEW FOR 2015

- In-depth Forums on Multibody Simulation and Durability & Fatigue, as well as Optimization
- The Latest on Our Product Updates
- More Technical Training than Ever
- Expanded Presence for Academics + Poster Contest
- More than 70 user presentations featuring Abaqus, fe-safe, Isight, Tosca and SLM
- Early Bird Registration Discounts
- Expanded Opportunities to Meet SIMULIA R&D

For more information, visit [www.3ds.com/SCC](http://www.3ds.com/SCC)

 **DASSAULT SYSTEMES** | The **3DEXPERIENCE**® Company